

Proudly Distributed by:
AAA Mailbox Sales & Service
"The Mailbox Guy"
Hutto, TX
www.mailboxguy.com

AF FLORENCE
manufacturing company
A GIBRALTAR INDUSTRIES COMPANY

vicinity™
MAIL STATION ACCESSORIES

sentinel™ solar site lite

Feel Safe and Secure, Day or Night

The Florence sentinel™ is a free-standing, pole mounted solar light system. It can be used as a site accessory for any pedestrian setting. The surface mount footing is also designed to wrap around Florence cluster box unit mailboxes.

Proudly Distributed by:
 AAA Mailbox Sales & Service
 "The Mailbox Guy"
 Hutto, TX
www.mailboxguy.com



Specifications

General:

- The light head design and positioning fully complies with the objectives of the International Dark-sky Association (IDA)

Construction:

- Pole: 1/8" wall thickness x 3" x 3" square steel tube
- Base: 1/4" steel construction
- Riser: 3/16" wall thickness x 2 1/2" x 2 1/2" square steel tube

Light Head Fork weldment:

- Tube: 3/16" wall thickness x 2" x 2" square steel tube
- Fork: 1/8" steel plate construction

LED Light Brick:

- Light output: 144 Lumens
- Amp draw: 360 mA
- Uses Nichia super-bright-white LEDs
- LEDs are enclosed in a vandal-resistant acrylic housing
- Light pattern: 12' wide x 6' deep at 12' from the ground

Battery:

- Sealed Lead-Acid
- 12 Amp-Hours

Solar Panel:

- Rated Power: 20 W
- Peak Power: 20 W
- Peak Power Voltage: 17.3 V
- Open Circuit Voltage: 21.7 V
- Short Circuit Current: 1.30 A
- Size: 1.31" x 19.8" x 16.7"

Motion Sensor:

- 12 volt
- Adjustable for activation time and sensitivity
- Red LED light provides visual indication that sensor unit is working
- Contains photovoltaic sensor that ensures LED lights only operate at dark, preserving battery life

Light head:

- One-piece thermoformed plastic housing
- UV-resistant ABS material
- Rain water/snow-melt is primarily discharged at the back of the housing
- All electrical components are located in the light head
- The light is installed in the housing such that the amount of horizontal light "trespass" is minimized to avoid disruption to neighborhood houses

Color Options

The sentinel™ solar site lite is available in 3 weather-resistant powder coat color options:

Sandstone
PMS 7501C

Black
PMS Blvd. 6C

Postal Grey
PMS 413C

Mounting Options



Surface mount base designed to fit around Florence cluster box unit mailbox pedestals

In-Ground Models

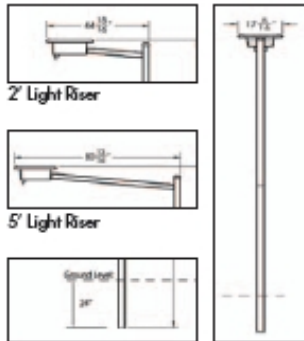

In-Ground Pole

Surface Mount Models

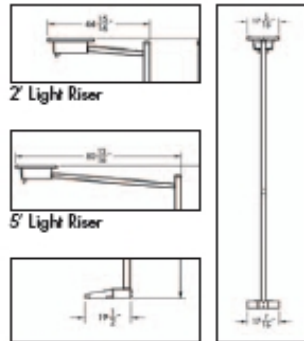

Surface Mount Base

2' Light Riser (In-Ground)

Height: 169-7/8"
 Weight: 129 lbs

5' Light Riser (In-Ground)

Height: 173"
 Weight: 146 lbs

2' Light Riser (Surface)

Height: 148-3/16"
 Weight: 137 lbs

5' Light Riser (Surface)

Height: 151-5/16"
 Weight: 153 lbs

Installation Photos

